

High-Precision Pneumatic Pressure Controller Series CPC 8000-M / -L / -X

WIKA Data Sheet CT 28.01

Applications

- Industry (laboratory, workshop and production)
- Pressure transmitter manufacture
- Calibration service companies
- Research and development laboratories
- National institutes and institutions

Special Features

- Pressure ranges: 0 ... 0.1 up to 400 bar, also as Dual range versions available (-DM/-DL/-DX)
- Pressure type: pos. & neg. gauge, absolute pressure
- Control stability: up to 0.001% FS
- Precision: up to 0.004 %
- Uncertainty of complete measuring chain: up to 0.008 % IS* acc. to EA 10/17 (or DKD-R 6-1)

* IntelliScale



High-Precision Pneumatic Pressure Controller CPC 8000

Description

Areas of application

With their 3 different accuracy classes (see specifications) the 3 pressure controllers CPC 8000-M/-L/-X or the dual range versions offer a suitable solution for any calibration task. They are available as desk tops or as 19" plug-in cases. These controllers have an outstanding control performance due to a special control valve technology and a pressure sensor with a very high long-term stability. The system is therefore particularly suitable as a factory / working standard for the calibration or testing of any pressure measuring instrument.

Functionality

In addition to entering the pressure set-point through the numeric key-pad, the pressure can be changed using either the STEP or JOG-keys. Moreover it is possible to create extensive test programs, which will run automatically or manually. The display, on which up to 4 windows can be viewed simultaneously, is very clear and easy to read.

Further features such as changeable control speed from 1 up to 100%, 3 programmable relay outputs, a data logger and various functions ensure that the controller can be used for many different applications.

Software

WIKA calibration and documentation software EasyCal is to make the calibrations of any type of pressure measuring instrument easy and enable calibration certificates to be produced. Furthermore the customer can also create his own test programs with the help of the software LabVIEW®.

Complete testing and calibration systems

An IEEE-488.2 and an RS-232 interface exists for communication with other instruments, and therefore the instrument can be integrated into an existing compound system, or on request customised mobile or stationary test systems can be manufactured.

Dimensions in mm

Desk top model

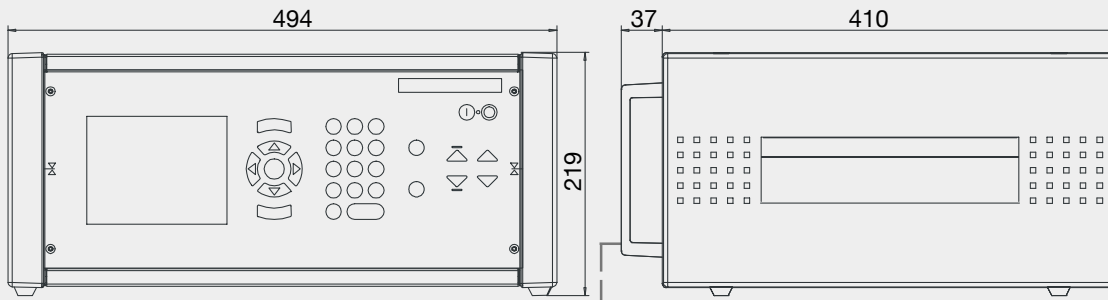

19" plug-in case

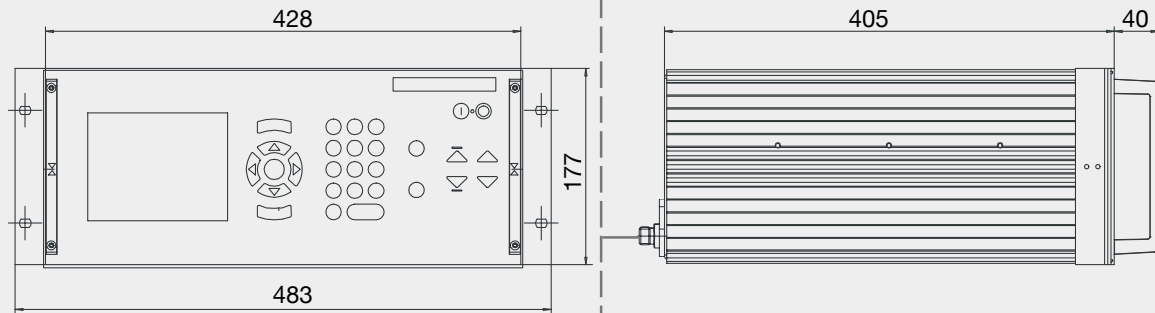

Rear view

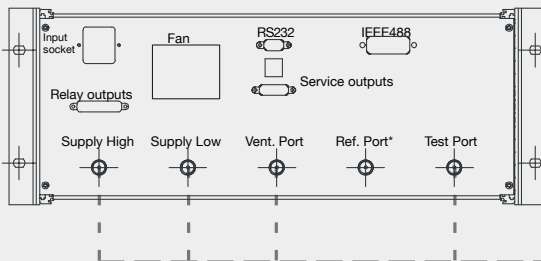

* optional

Optional adapter

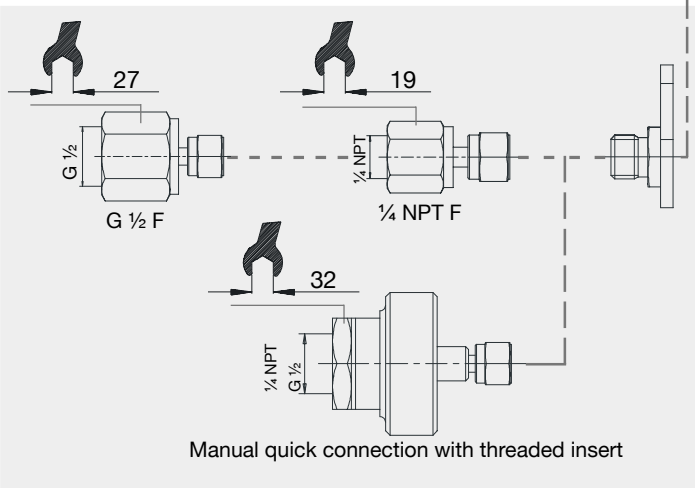

Pressure ports:
6 mm SWAGELOK® tube fitting

Specifications for the different pressure steps for CPC 8000-M /-L /-X

Pressure range for CPC 8000-M /-L /-X		CPC 8000-M	CPC 8000-L	CPC 8000-X
Low Pneumatic Pressure Ranges	bar	0 ... 0.25 up to 0.6 *	-	0 ... 0.1
Precision	%	0.012	-	0.004
Uncertainty	%	0.025 FS	-	0.008 FS
Control stability	%	0.0025	-	0.001
Slew rate	sec	< 20	-	< 20
Standard Pneumatic Pressure Ranges	bar	0 ... 1 up to 40 *	0 ... 1 up to 40 *	0 ... 1 up to 34 *
Precision	%	0.012	0.005	0.004
Uncertainty	%	0.025 FS	0.01 FS	0.008 IS ¹⁾
Control stability	%	0.0025	0.001	0.001
Slew rate	sec	< 15	< 15	< 15
High Pneumatic Pressure Ranges	bar	0 ... 60 up to 250 *	0 ... 60	0 ... 70 up to 210 *
Precision	%	0.025	0.005	0.005
Uncertainty	%	0.05 FS	0.01 FS	0.01 IS ²⁾
Control stability	%	0.005	0.001	0.0012
Slew rate	sec	< 25	< 25	< 25
Highest Pneumatic Pressure Ranges	bar	0 ... 400	-	0 ... 400
Precision	%	0.025	-	0.005
Uncertainty	%	0.05 FS	-	0.01 FS
Control stability	%	0.005	-	0.002
Slew rate	sec	< 35	-	< 35

{Absolute pressure range: 0 ... 1 bar up to 0 ... 16 bar *}

* For concretely available pressure ranges see current price list.

1) IntelliScale => % of measured value in the upper 2/3 of the pressure range.

2) IntelliScale => % of measured value in the upper half of the pressure range.

General specifications

CPC 8000-M /-L /-X

Control range	% FS	0 ... 100
Test volume	ccm	50 up to 1000 (without throttle; Leakage < 10 ⁻³)
Pressure ports		6 mm SWAGELOK® tube fitting
Adapter		on request
Overpressure protection		safety valves, scaled to 120% of FS
Instrument version		19" plug-in case (optional: desk top)
Screen		TFT-Colour graphics display (320 x 240 Pixel)
Screen division	windows	1, 2 or 4
Indication of measured values	digits	up to 7
Measuring rate	values/sec.	8
Keyboard		Membrane keyboard
Evaluation unit		Motorola 50 MHz Power PC-Board
Operating system		Windows CE
Digital interface		RS-232 and IEEE-488.2
Relay outputs		3 programmable change-over contacts (potential free)
Power supply		AC 230 V ± 10 %, 50/60 Hz; 0.75 A (optional: AC 115 V)
Permissible pressure		
Supply high port	% FS	100 ... 110 (measuring range ≤1 bar: approx. 2 bar supply pressure)
Test port	% FS	max. 120
Permissible		
Media		clean, dry air or nitrogen
Operating temperature (ambiente)	°C	15 ... 35
Storage temperature	°C	0 ... 70
Air humidity	%	35 ... 85 relative humidity without moisture condensation
Ingress protection		IP31 (front panel IP41)
Weight	kg	approx. 17
Dimensions		see technical drawings
CE-mark		conformity certificate
Calibration ³⁾		Incl. calibration report 3.1 according to DIN EN 10 204

3) Calibration in a horizontal mounting position.

Performance Features of the CPC 8000

Excellent control performance

The main highlight of the CPC 8000 High-Precision Pressure Controller is their excellent control performance. The CPC 8000 ensures fast and harmonic pressure control without any overshooting and features excellent control stability.

Especially adaptive to any application

The controller has an unbeatable WARM-UP time of less than 1/2 hour. Furthermore an adaption to the test volume can be carried out by using the menu-point 'Controller Adaption', and, if necessary, a head pressure correction between the device under test and the CPC 8000 can be made through the interface."

The control speed can be reduced to only 0.1 % of the maximum speed, so that it is possible to carry out controls extremely carefully and smoothly where necessary (e.g.: pressure switch tests).

Comfortable to work with

The generally straightforward and lean structure of the menu guarantees a very high degree of operator convenience.

User-friendly display

Up to 4 windows can be viewed simultaneously on the large colour graphics display. Each window can display a value with up to 7 digits. The respective pressure unit can be selected from 17 stored standard units or from 3 user-defined units.

Long-term stability

Due to its top quality pressure sensor the instrument offers an outstandingly high precision and signal stability. Furthermore a special valve technology ensures almost soundless and wear-resistant controlling.

Useful menu functions

- Minimum-Storage
- Maximum-Storage
- Hold
- ZERO
- Average
- Limits with visual alarm
- Pressure rate (pressure change / time)
- Offset correction

Further features

- Integrated Data logger (up to 999 values)
- 3 programmable relay outputs
- IEEE and RS-232 Interface
- Optional: barometric reference

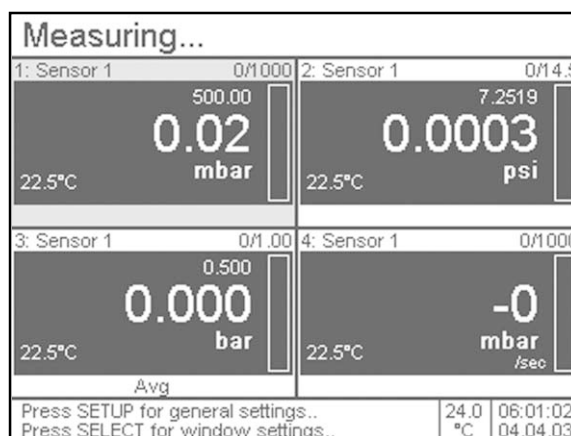
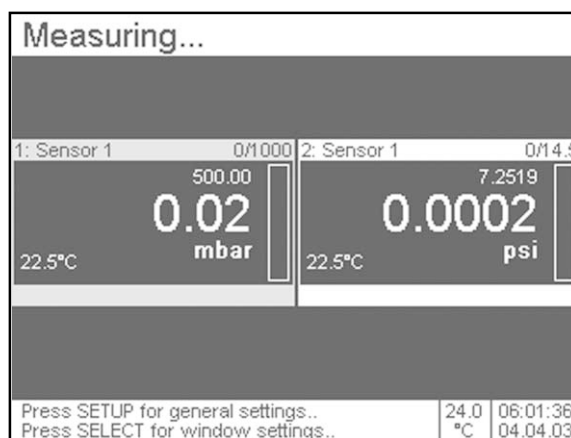
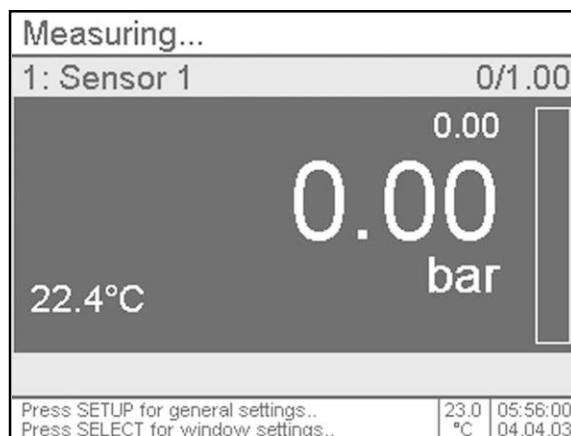

Examples of different display modes

Measure and Control Mode

Selection of operation mode

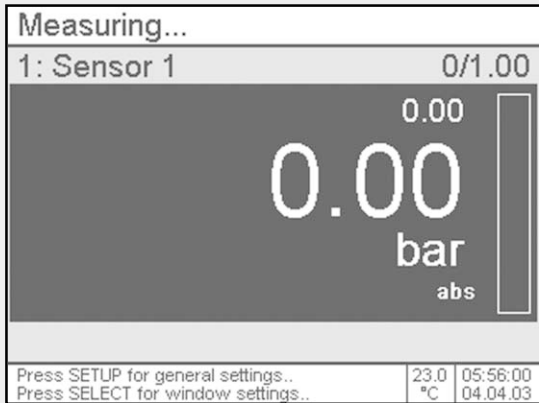

In the measure mode, the instrument measures the pressure connected to the test port very precisely.

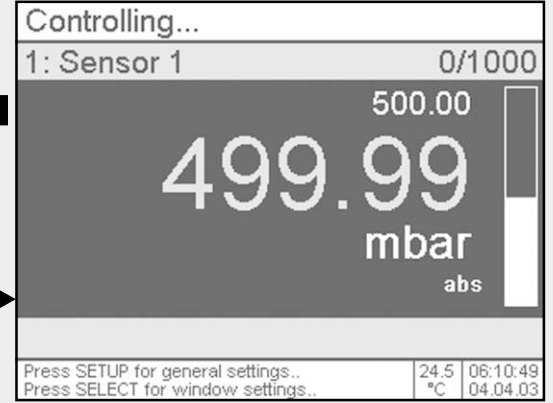

In the control mode the instrument provides a very precise pressure (0 ... 100 %/FS) at the test port.

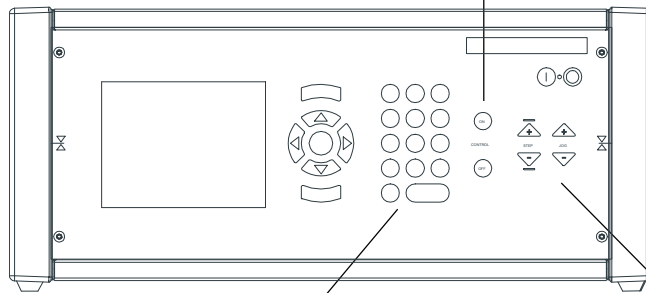
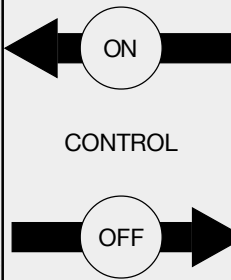

Controlling a certain pressure

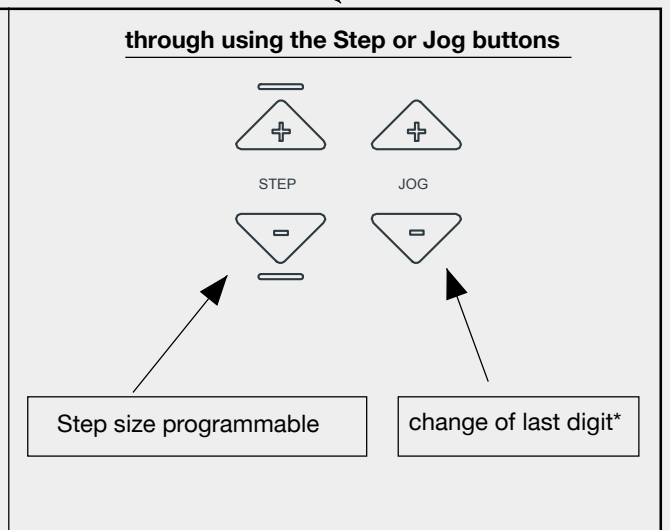
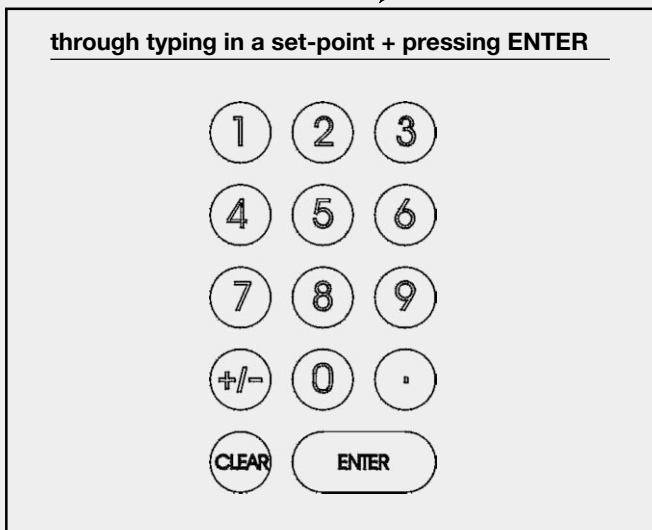

A colour change of the displayed value from white to green signals to the user that the pressure applied is within the tolerance range.

*Decimal places can be faded in or out. Max total amount of displayed digits including decimal places is 7.

Operating principle of a dual-range controller

A dual-range controller features a second sensor in addition to the main sensor (sensor 1) in order to improve the accuracy in the lower part of the pressure range.

Dependent on the required pressure the dual-range controller automatically and intelligently selects the proper measuring range, regardless of whether the set value was entered via membrane keypad or interface.

The precision pressure sensors are combined flexibly according to the requirements of the customer.

In order to cover a wide calibration range it is even possible to combine 2 sensors with a factor of up to 1:10 regarding their ranges.

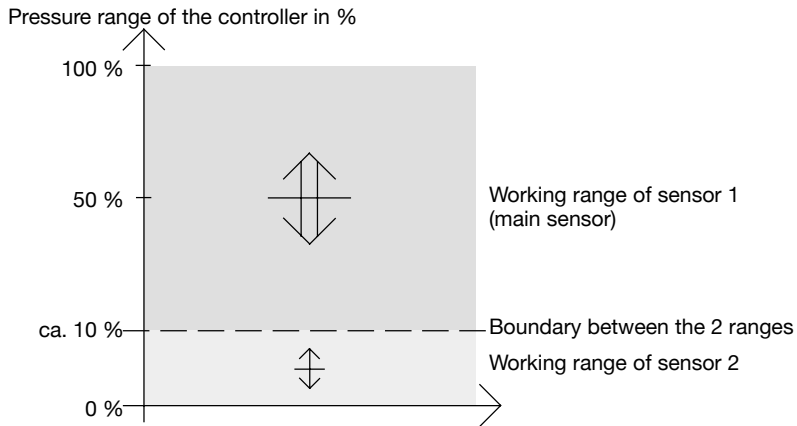

Example of a changeover from one sensor to the other

a) starting point (start) in the working range of sensor 1 (main sensor)
new pressure (target) in the working range of sensor 2

b) starting point (start) in the working range of sensor 2
new pressure (target) in the working range of sensor 1 (main sensor)

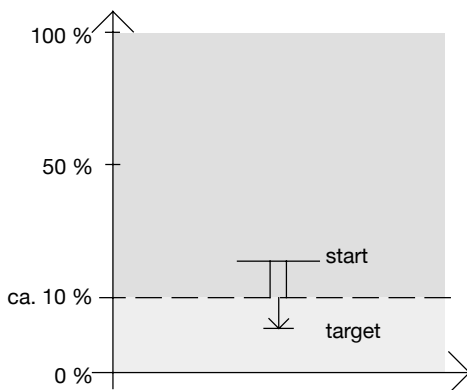

Changeover from sensor 1 to sensor 2 at the range boundary

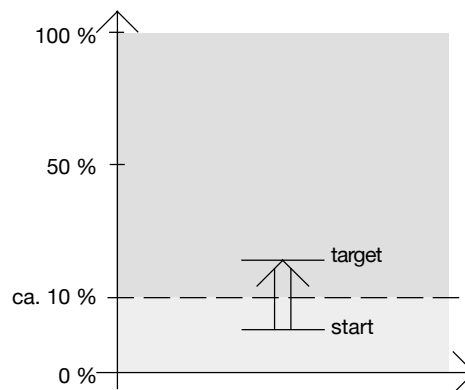

As soon as the control process for the new pressure is started, sensor 1 (main sensor) will be used as a reference, because the target is within the range of this sensor (sensor 2 will be not used in this case).

Automatic calibration through CPC 8000 and PC Calibration Software EasyCal

The WIKA calibration software has been developed for the calibration (testing device monitoring) of mechanical and electronic pressure gauges according to ISO 9000.

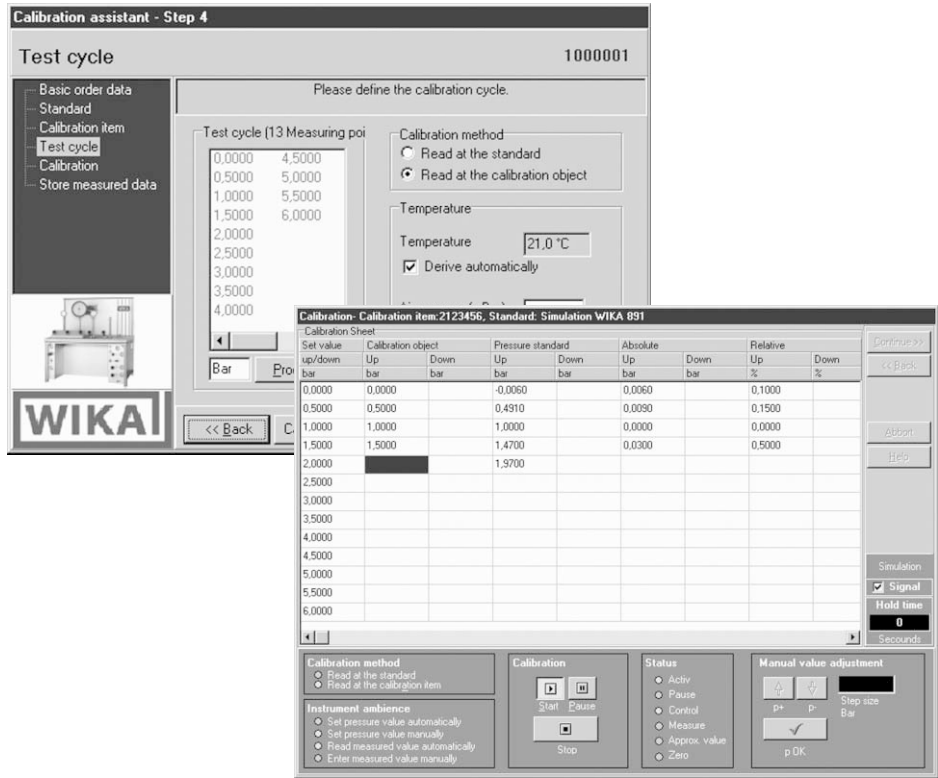

The software offers:

- Calibration assistant that guides through a calibration
- User-friendly menu
- Automatic generation of calibration steps according to EN 837-1
- Certificates 3.1 in accordance with EN 10 204
- Customised test protocols possible (Access Report-Designer)
- Archiving of calibration data as well as device management via Access database
- Language: English/German

DEMO-Version available (free of charge)

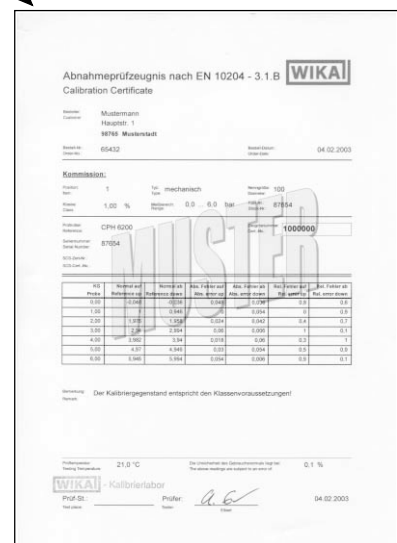

Wiring details

The input socket and the digital interfaces (see Rear view on Page 2) may only be connected with specific connection cables approved for this purpose.

Relay outputs (3 potential free change-over contacts)

Condition of wiring scheme as shown: inactive

Output capacity of relays: max. 1 A / 30 VDC

(Pin 10 to 25 should not be used)

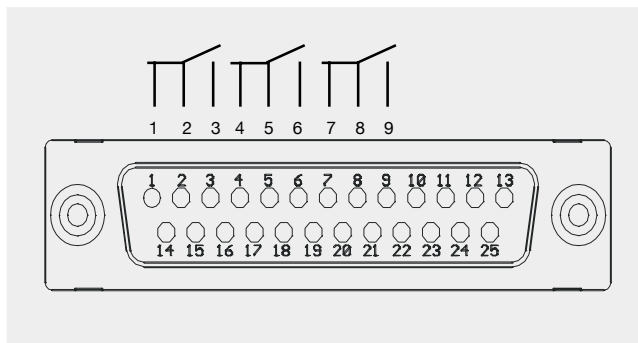

Scope of supply

- Precision Pressure Controller CPC 8000 (19" plug-in case)
- Mains cable 1.5 m with mains plug
- Operating instructions in English
- Calibration report 3.1 according to DIN EN 10 204

Options

- DKD certificated accuracy
- Dual range versions CPC 8000 - DM / -DL / -DX
- Device in rugged desk top housing
- Barometric reference
- Complete testing and calibration systems

Accessories

- Rugged transport box (aluminium)
- Pressure adapter and manual quick connection adapter
- Interface cable
- Calibration software EasyCal
- Service tools



Application example

Products and Services within our Testing and Calibration Technology Program

- DKD calibration services for pressure
- Repair of calibration units of all makes
- Portable pressure measuring devices for testing and calibration tasks
- Precision pressure measuring units and pressure controllers
- Primary standards for pressure
- Testing technology system solutions
- DKD calibration services for temperature
- Temperature dry well calibrators
- Calibration baths and furnaces
- Temperature measuring instruments for testing and calibrating tasks
- Precision thermometers
- Primary standards for temperature
- Consulting and training

Specifications and dimensions given in this leaflet represent the state of engineering at the time of printing. Modifications may take place and materials specified may be replaced by others without prior notice.

